

EKATO SOLIDMIX VPT/VST

Function

The base model consists of a jacketed vessel for cooling/heating with water. The use of different EKATO impellers allows testing of multiple applications. Both the EKATO PARAVISC impeller for free-flowing solids and the EKATO ISOPAS impeller for pasty products are available.

Working limits

Pressure: -1/+2 bar(g)
Temperature: up to 131°C

Materials

- Stainless steel, others on request

Vacuum system

- Laboratory membrane vacuum pump with condenser and condensate vessel

Utility

- 3 x 400V, 50Hz (min. 16A)
- others on request

General Features

- Designed for scale-up and formulation purposes
- Design corresponding to production scales with equal mixing systems
- Pressure and vacuum service
- Electrical controls with touch screen
- Electrical lid lifting device
- Data logger on request
- Interface for PC/remote data transfer on request
- Rental unit available
- Product temperatures up to 131°C



↑
EKATO VPT25/VST50

↓
EKATO VPT3/VST5

Features

In addition to the well-proven EKATO Solids-PARAVISC for mixing and drying of free-flowing bulk materials, a EKATO VPT impeller for pasty products is always included in the scope.

As a special feature, almost all available impellers can be provided on demand, including but not limited to double helix, archimedes screw and hydrofoil liquid impellers.



VST: EKATO Solids-PARAVISC



VPT: EKATO ISOPAS with baffle

Dimensions

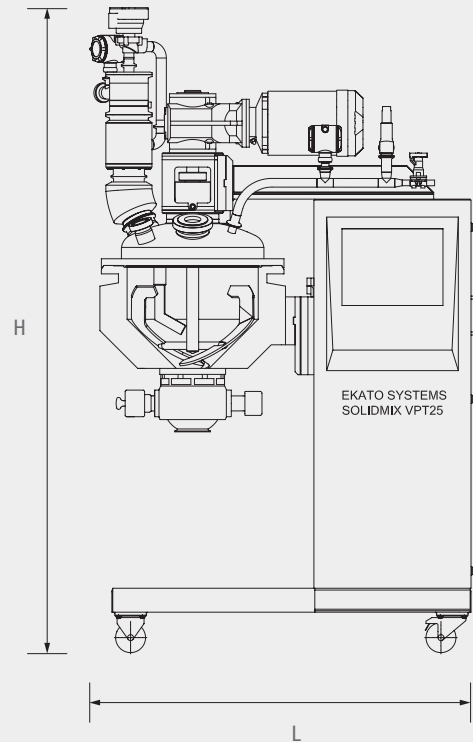
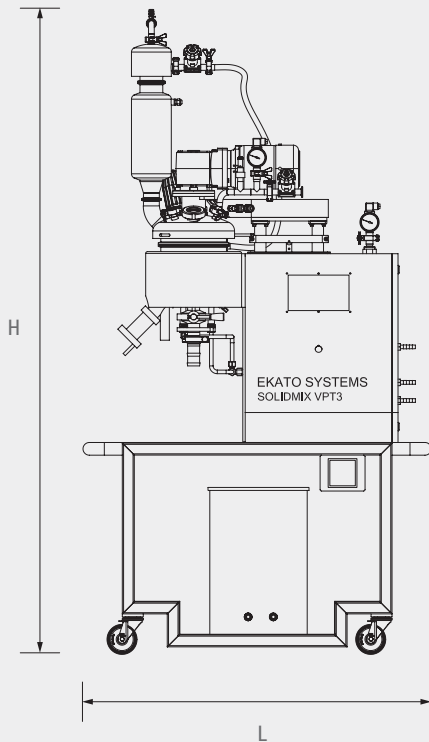

Size	Useable volume (l)	Length L (mm)	Width B (mm)	Height H (closed) (mm)	Weight (kg)
VPT 3	1-3	1000	800	2150	120
VST 5	1-5	1000	800	2150	120
VPT 25	5-25	2151	750	1800	180
VST 50	10-50	2151	750	1800	180

Approximate dimensions. Technical data are subject to changes. For information only. Do not use for construction unless certified.